

VCO: Voltage Controlled Oscillator

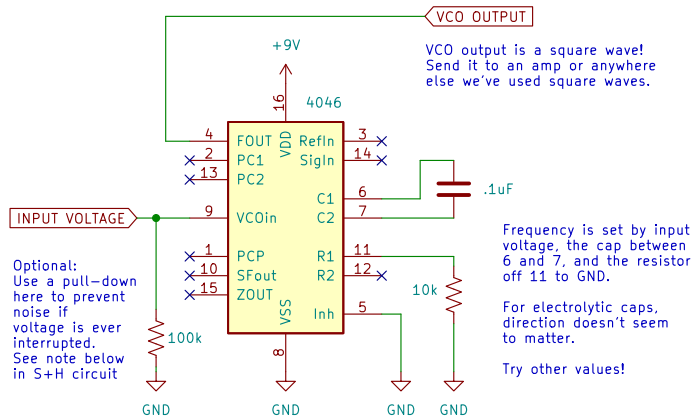

Voltage Divider

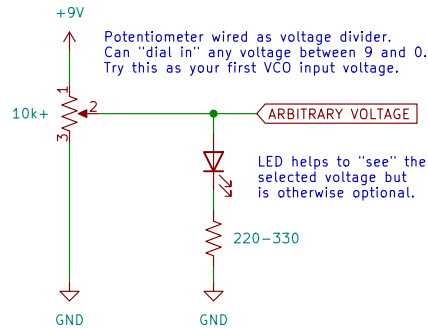

Triangle Wave

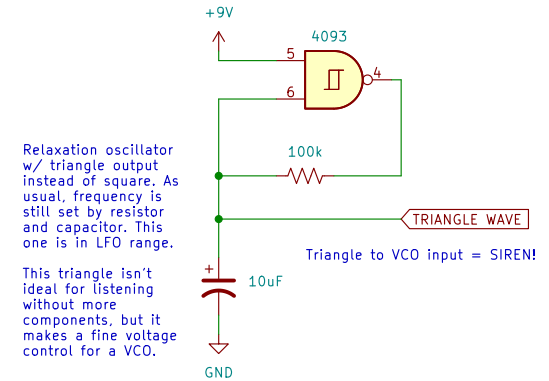

Sample and Hold

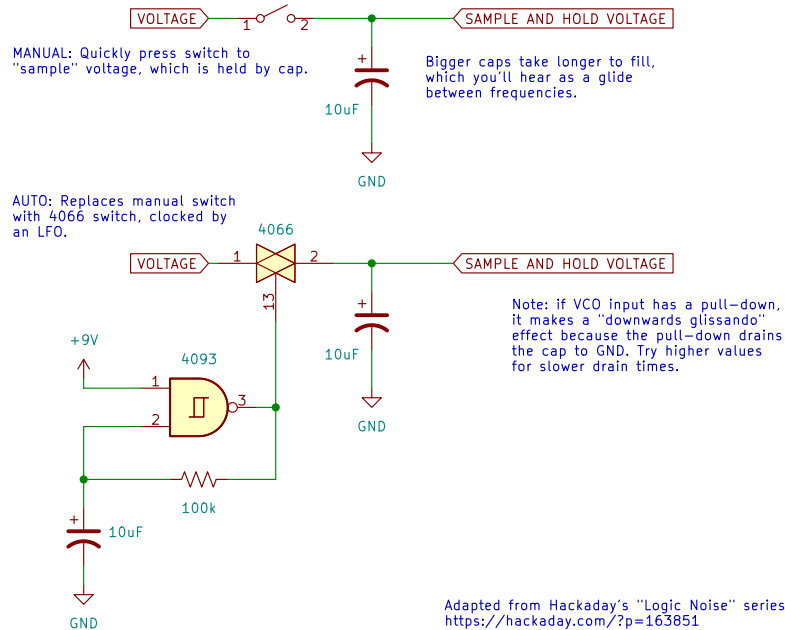

Glide

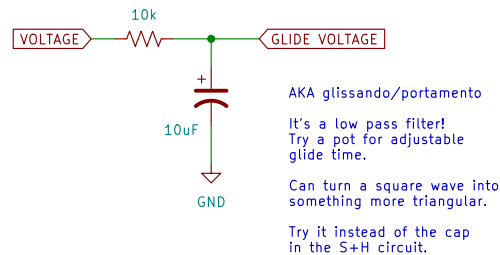

Voltage Keyboard

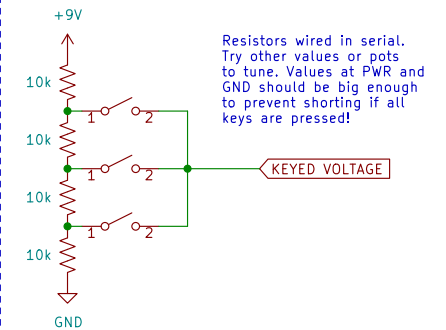

tommy@oskitone.com

Sheet: /sample_and_hold/

File: sample_and_hold.kicad_sch

Title: 4046 VCO Circuits

Size: A4 Date: Sept '23

KiCad E.D.A. kicad (6.0.1-0)

Rev:

Id: 12/12